

REINHOLD ENVIRONMENTAL Ltd.



2010 APC Round Table & Expo Presentation

July 18-20, 2010, in Concord, NC / Hosted by Duke Energy

All presentations posted on this website are copyrighted by Reinhold Environmental, Ltd (RE). Any unauthorized downloading, attempts to modify or to incorporate into other presentations, link to other websites, or obtain copies for any other uses than the training of attendees to RE's Conferences is expressly prohibited, unless approved in writing by RE or the original presenter. RE does not assume any liability for the accuracy or contents of any materials contained in this library which were presented and/or created by persons who were not employees of RE.

APC Roundtable

Mid Frequency Power Supplies for ESPs

Roland Metz, Siemens Industry, Inc.
Dr. Michael Steingraeber, Siemens AG

SMPS – Switch Mode Power Supply Medium Switching Frequency

SIEMENS

The requirements for the development of the first 3-phase AC SMPS with power semiconductors (transistors) in 1988 were:

- Generation of a flat DC voltage up to 110kV
 - Rated power up to 200kW
 - Fast spark detection/reaction to avoid over current at short circuit conditions (spark, flash-over) and for fast ESP recovery
 - High availability for harsh ambient conditions at the installation site (temperature, gas conditions, dust ..)
- This led to the development of the first SMPS inverter system based on transistors with 1kHz switching frequency rated for 200kW and with standard separation of control cabinet and T/R set.



SMPS – Switch Mode Power Supply Medium Switching Frequency



Today, after more than 20 years experience with SMPS, the technical requirements are:

- SMPS rated power up to 200kW and higher
- 3-phase input voltage 380V up to 690V
- ESP voltages up to 150kV due to the tendency for increased ESP gas passage
- High signal sampling rate for fast scan and reaction to sparks/arcs
- Integrated optimization functions to maximize ESP efficiency at all operating conditions
- Easy accessibility of all components and high availability even at poor ambient conditions
- Reuse of existing 60Hz T/R sets as low cost upgrade solution
- Quick determination of the advantage with SMPS IGBT based power supply at existing ESP installations

SMPS – Switch Mode Power Supply IGBT Control with Medium Switching Frequency



Available up to
275kW

3 phase main



1 phase, 500Hz

or

1 phase, 60Hz

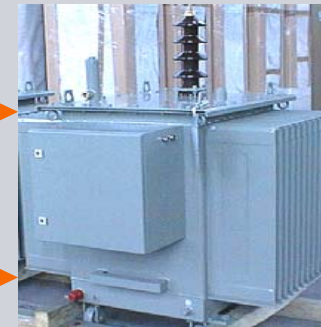

New, special
500Hz T/R-set

or
Reuse of existing
60Hz T/R-set

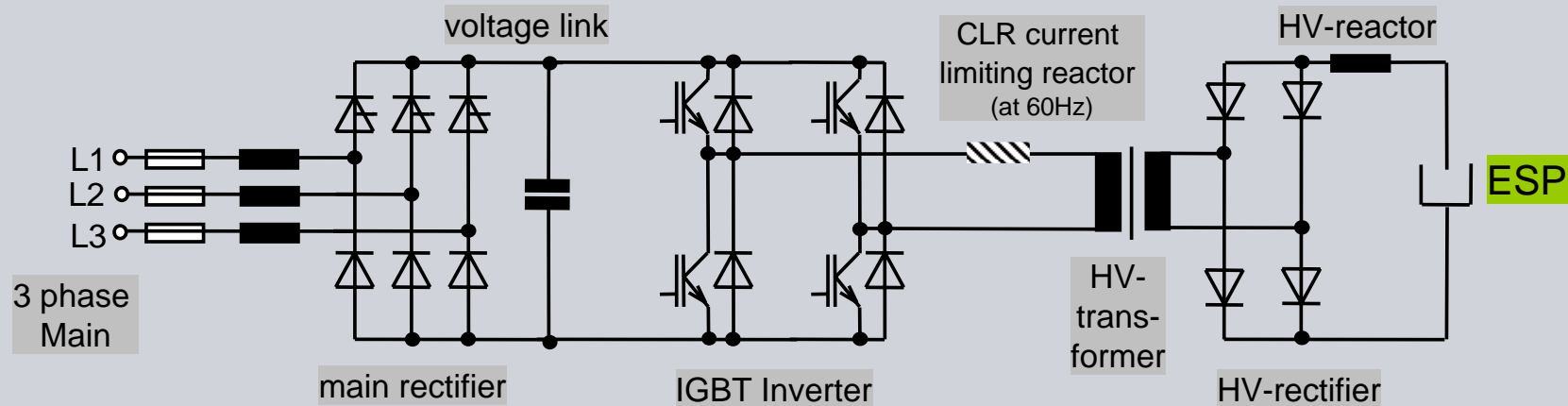

Comparison SCR (60Hz) – SMPS (500 Hz)

Conventional thyristor control (SCR - silicon controlled rectifier):

- Max. ESP voltage and current limited by ESP discharges

SMPS - IGBT Inverter

- Ripple extremely small due to short switching times
- Increased average voltage and current
- Substantial increase of corona power

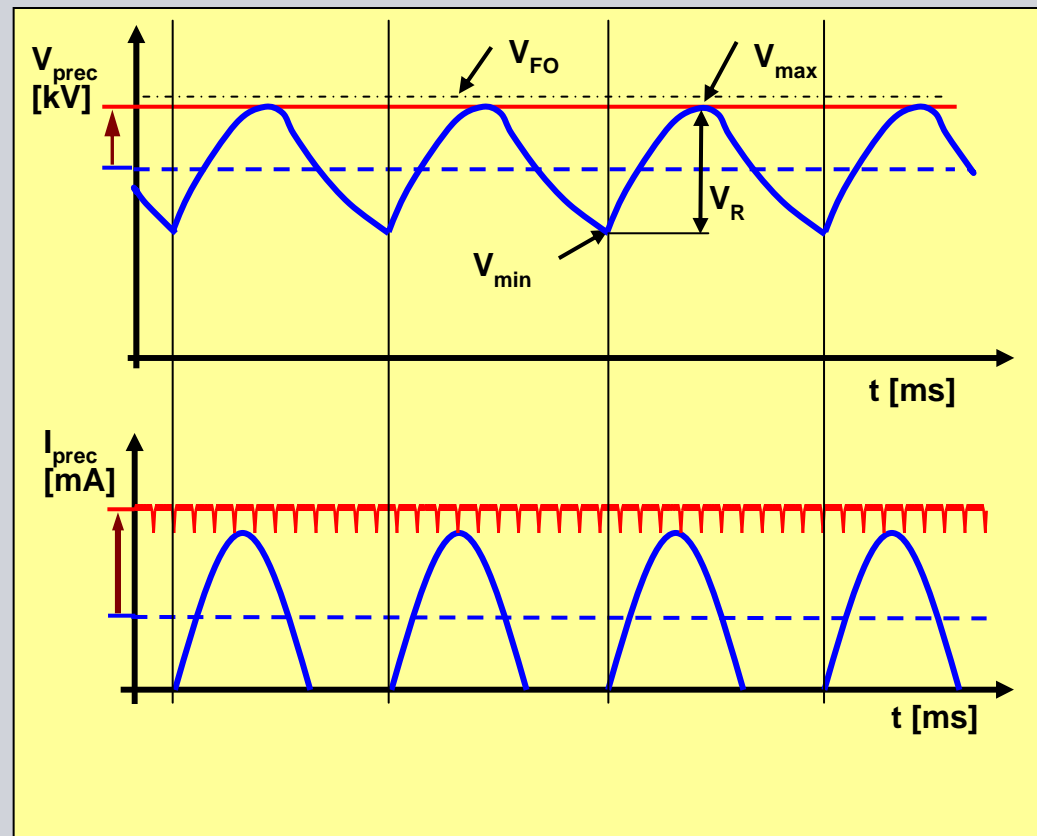

➤ **Increased ESP efficiency**

Comparison of thyristor (blue) and IGBT power supplies (red) voltage/current curves

Comparison SCR (60Hz) – SMPS (500 Hz)

- IGBTs can be switched independently
 - Almost no over current at flash-over
 - Short deionization time
 - Fast recovery of ESP voltage/current
- **Increased corona power during spark processing**
- **Insensitive ESP operation even during process disturbances**

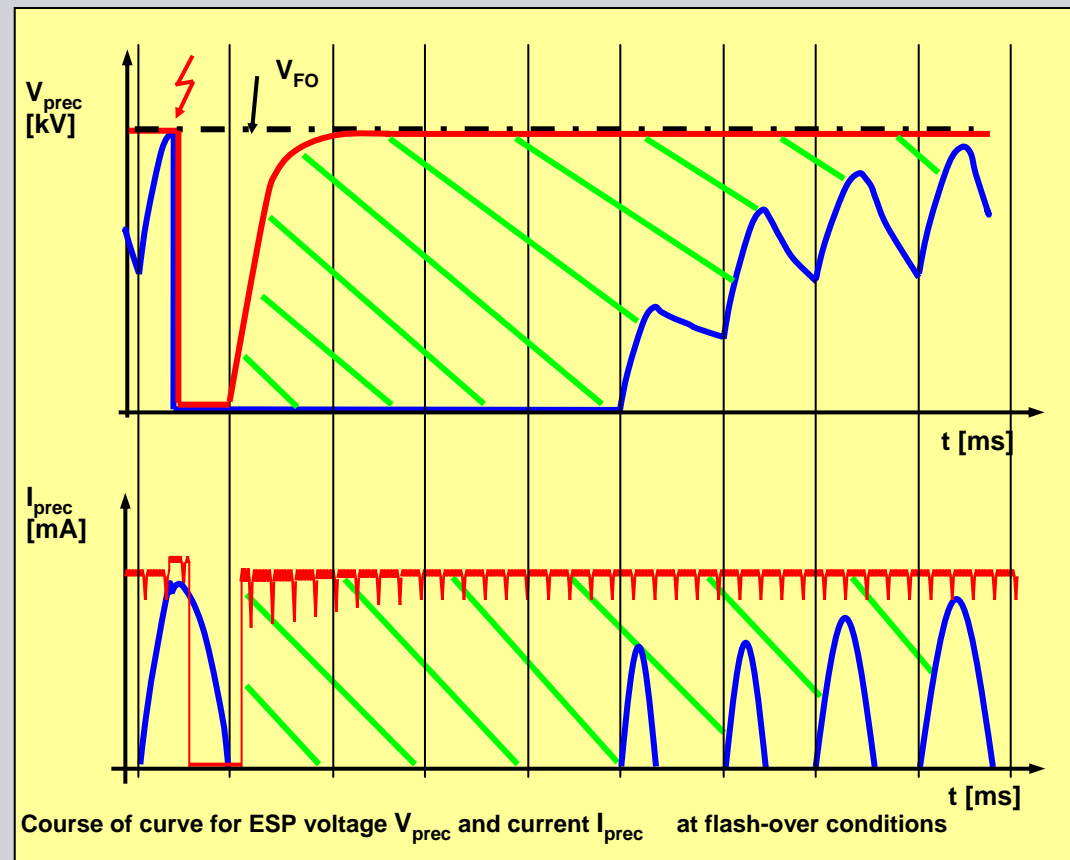

Comparison of Thyristor (blue) and IGBT power supplies (red) voltage/current curves during flash-over processing

Comparison SCR (60Hz) – SMPS (60 Hz)

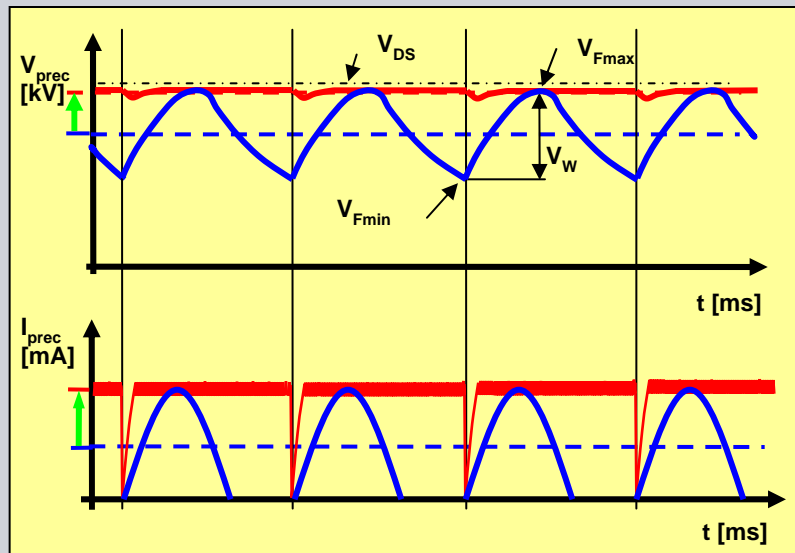

Curves for ESP voltage VF and current IF of Thyristor (blue) and IGBT (red) power supplies

- Reduced ESP voltage ripple
- Increased corona power
- 3 phase connection
- Power factor close to 1
- Reduced modernization costs with reuse of existing T/R-sets

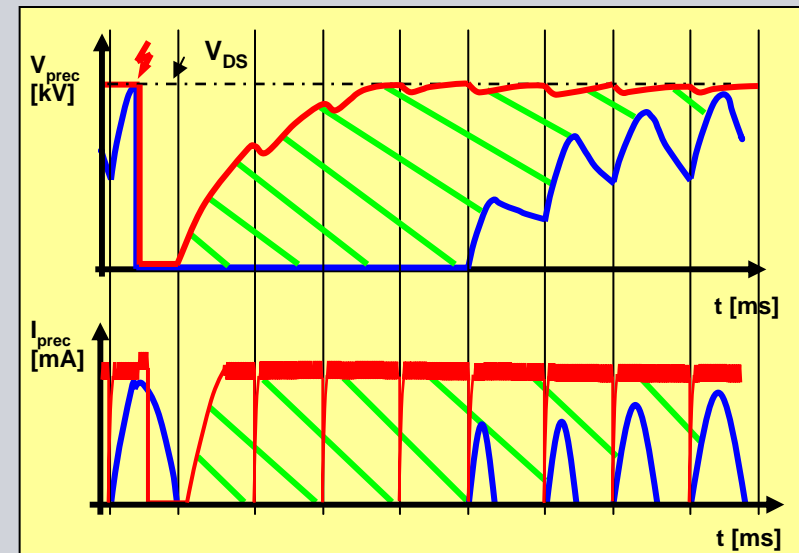

Curves for ESP voltage VF and current IF at flash-over conditions

- Reduced short circuit current
- Decreased deionization time / fast recovery of ESP voltage/current
- Increased performance during flash-over processing

ESP Operating Characteristic

Situation A:

Typical for all inlet fields and small ESPs. Corona power limited due to sparks. Potential for **SMPS**

Situation B:

Typical for large ESPs and/or low production rate. Potential for **energy savings**

Situation C:

Back corona conditions where corona power must be controlled with **pulse mode**

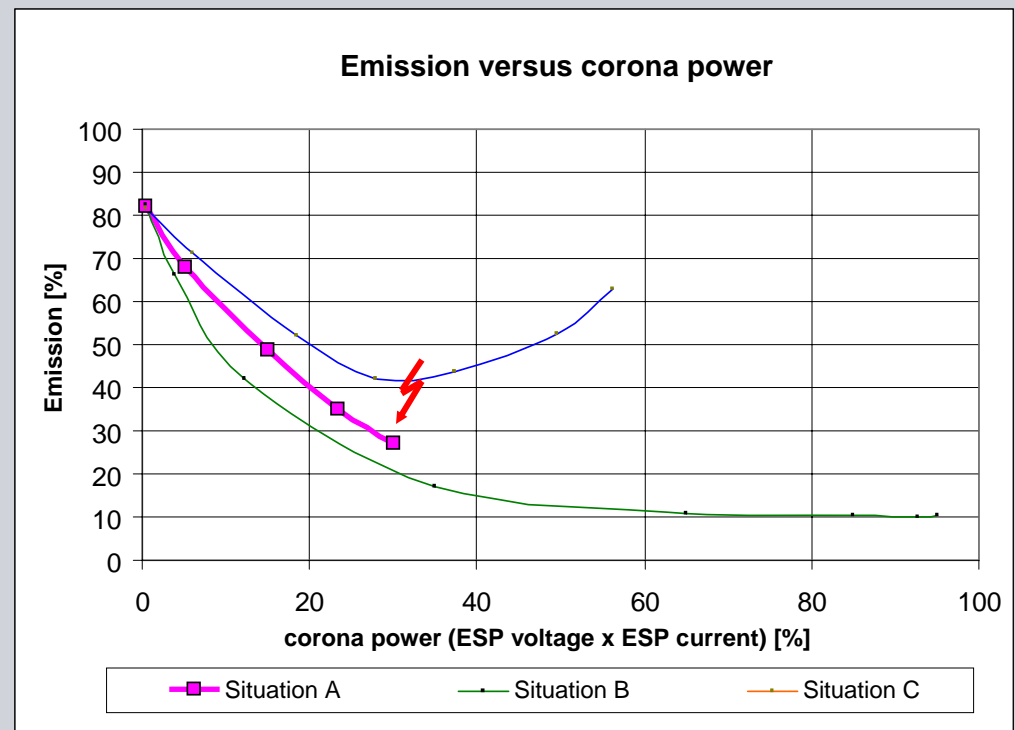

SMPS – Switch Mode Power Supply

Determine the Potential prior to Investments

- Simple pre-test with the existing equipment:
 - Opacity signal recording
 - Scanning of static I/V curve
 - Determination of max. ESP voltage/current with SMPS
 - Graph opacity = f (corona power)
 - Determination of opacity decrease

- Trial installation for performance check at real operating conditions

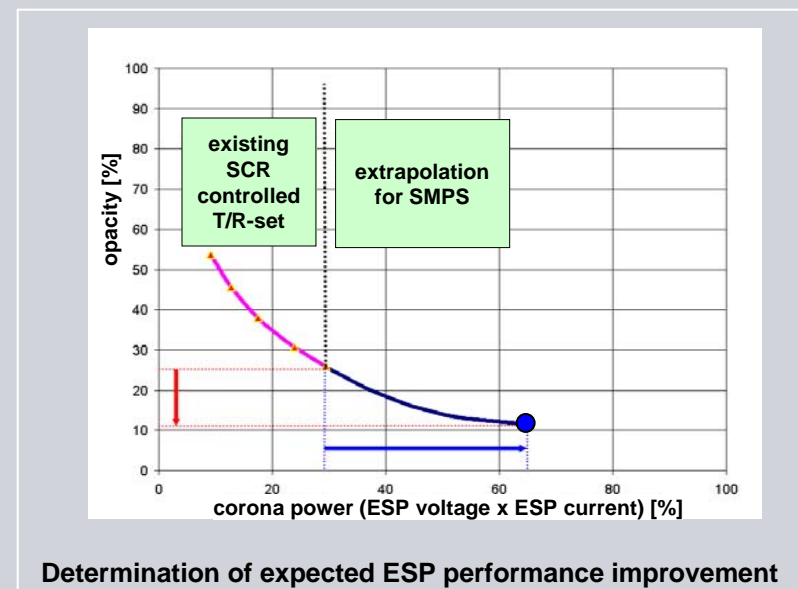
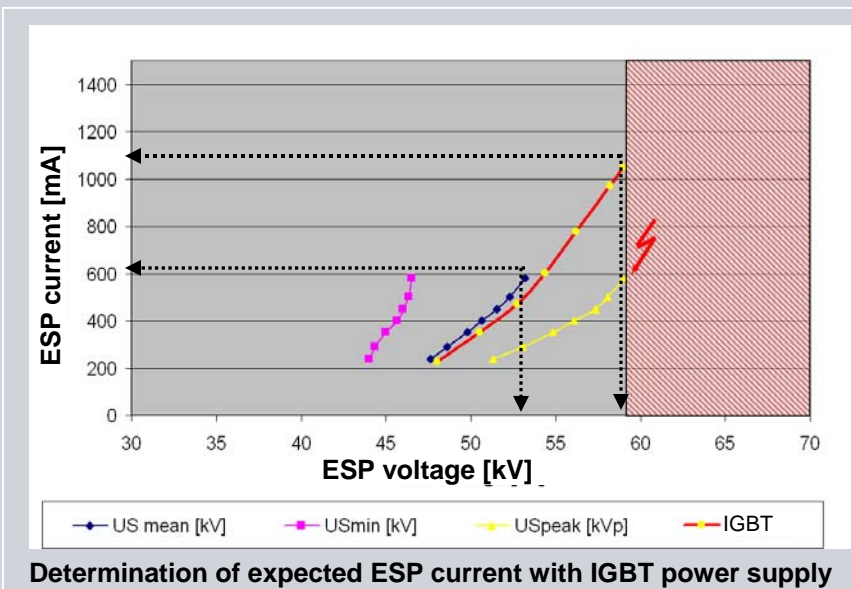

Comparison SMPS types

High Frequency – Medium Frequency (1)

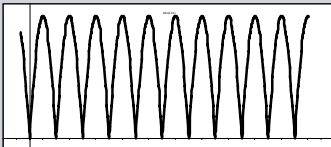
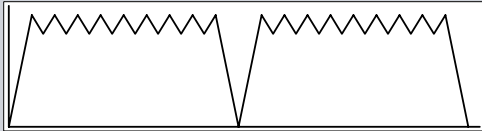
Properties:	Resonant (HF)	Hard switching (MF)
Type:	High Frequency	Medium Frequency
Current waveform:		
Input Phases:	3	3
Power Factor:	~ 1	~ 1
Operating frequency:	high (e.g. 20kHz-80kHz)	moderate (500 Hz / 10 kHz)
T/R-set operating frequency:	20 kHz – 80 kHz special TR required	- 500 Hz (optimum) - 60Hz using standard T/R sets
Switching losses:	Low energy losses per switching event, but higher frequency	Higher energy losses per switching event, but lower frequency
Power losses:	High (fast IGBT needed, higher V_{CE0})	Low (high current type IGBT, lower V_{CE0})

Comparison SMPS types

High Frequency – Medium Frequency (2)



Properties:	Resonant (HF)	Hard switching (MF)
Power supply upgrade:	Always replace inverter and T/R-set	Reuse of existing T/R-sets possible
T/R-Set type:	Low losses (Ferrite)	500 Hz or standard 60Hz
T/R-Set size:	Small for the same power rating compared to standard T/R set but limited as high voltage requires insulation distance.	Little smaller compared to standard T/R set
Distance Inverter – T/R-Set:	Not possible due to high frequency	- 500 Hz T/R-set: <u>120m (~400 ft)</u> - 60Hz T/R-set: <u>any</u>
T/R-Set core	small, Ferrite	Iron plates
Maximum power:	120 KW	<u>300 kW and higher</u>
Maximum voltage:	70 – 100 kV (DC)	<u>150kV</u> (DC) and higher possible
Maximum current:	1.7 A (with 70kV max.)	3.3 A (with 90kV max.)
Spark reaction:	fast	fast
Spark current increase:	no	no

SMPS – Switch Mode Power Supply IGBT Controller components

IGBT Control cabinet

T/R-set

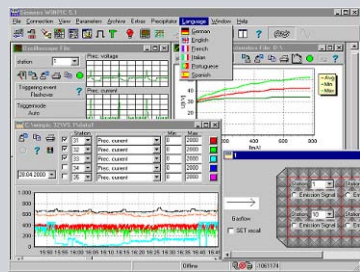

Operating and diagnostic Software



Operating panel Touch screen

micro-controller PIC 167-1

4 digital inputs
2 analog in-/outputs
5 Relay-outputs

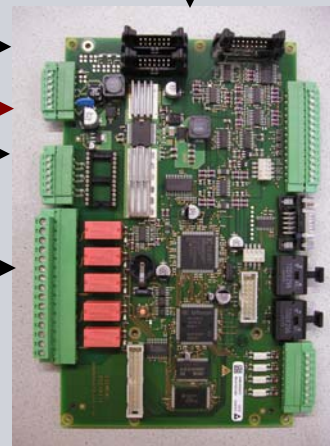

signals [mA], [kV], [T/R-set protection] via optical fiber cable

HV-acquisition unit PIC HS 115-2

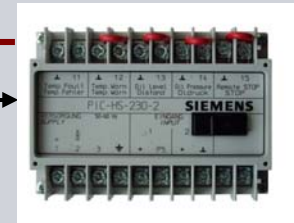

power supply integrated at fiber optical cable



SITOP power supply

GAX 167 main rectifier control

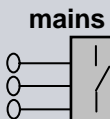
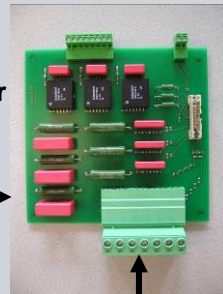

mains

Breaker / Fuses

commutating reactor

main rectifier

Voltage link

IGBT-inverter

IGBT Assembly

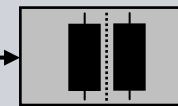

HV-transformer

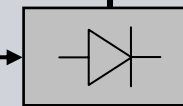

HV-rectifier

ESP

SMPS – Switch Mode Power Supply Power Electronics

SIEMENS

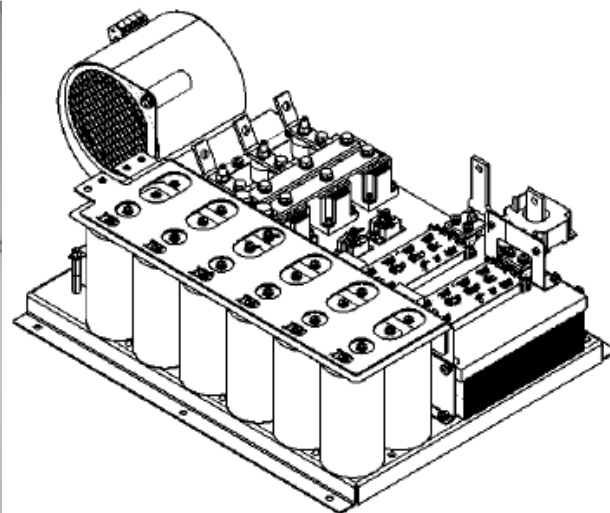
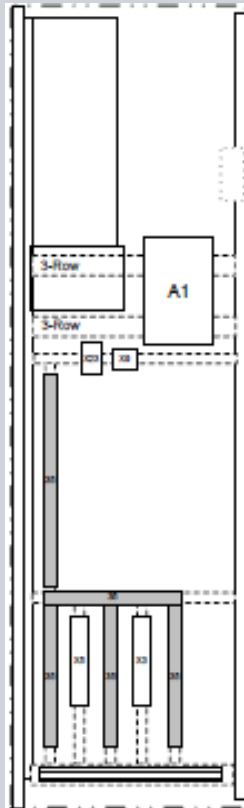

SMPS – Switch Mode Power Supply Typical Operating Wave Forms (500Hz)

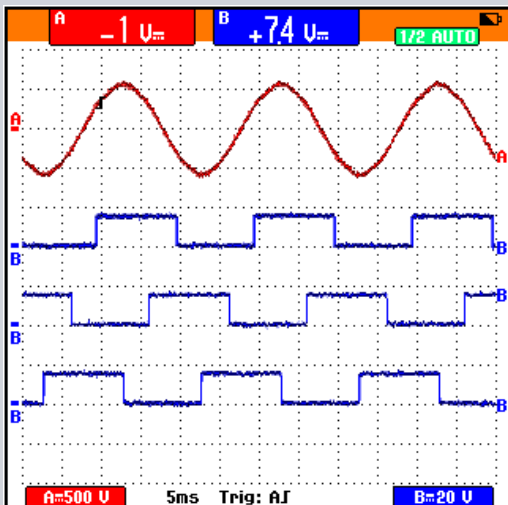
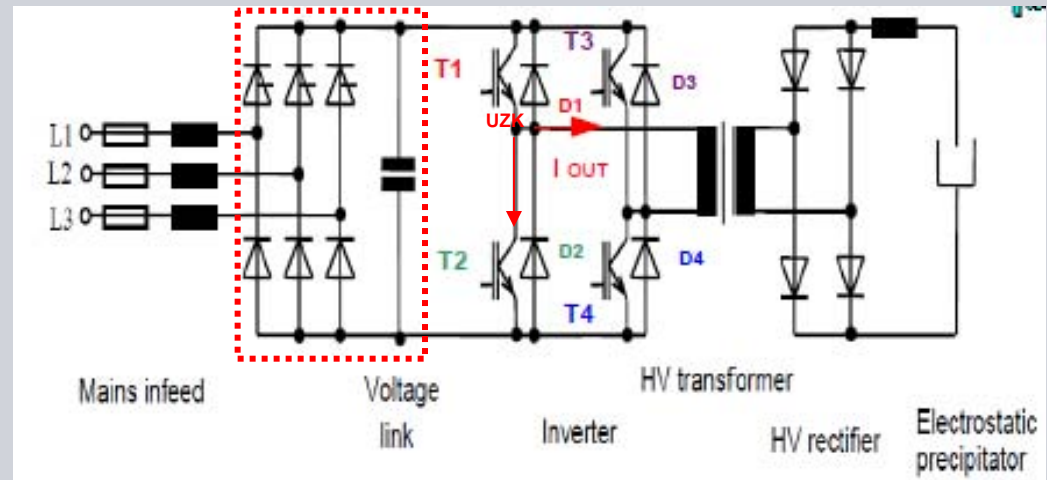
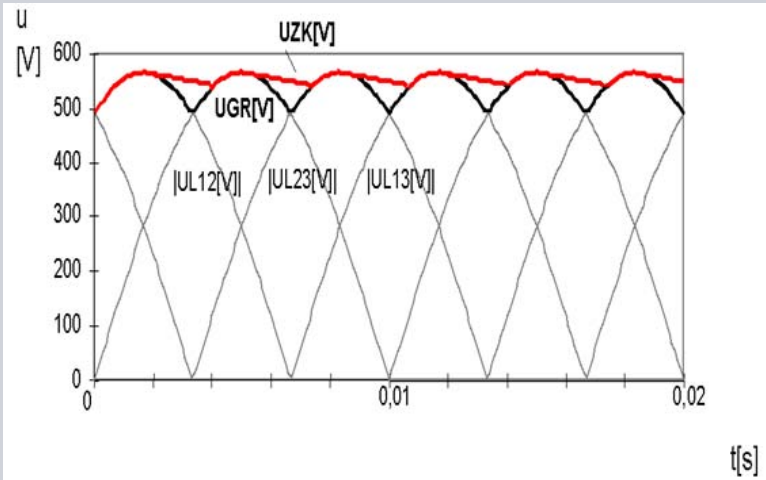

Phase L1-L2

Gate L1

Gate L2

Gate L3

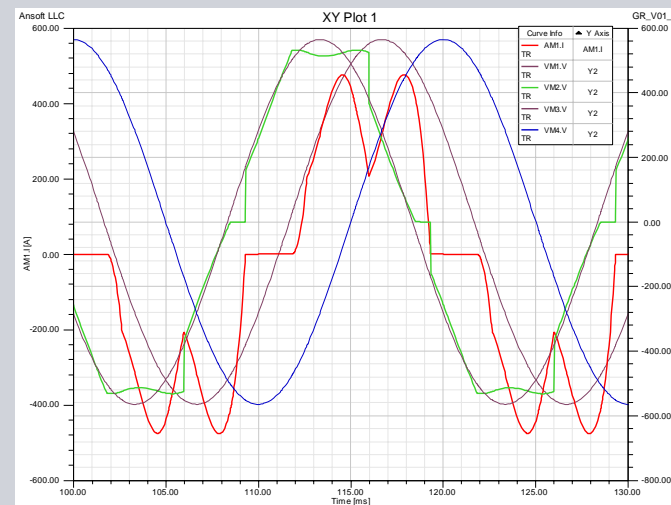

$I_1 = 365 \text{ A}$

SMPS – Switch Mode Power Supply Typical Operating Wave Forms (500Hz)

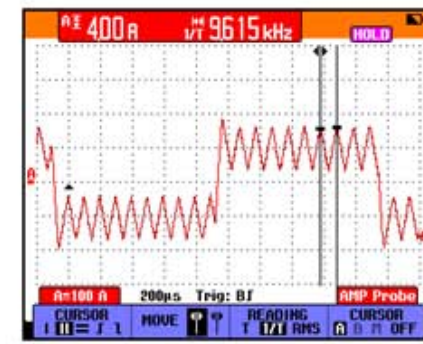
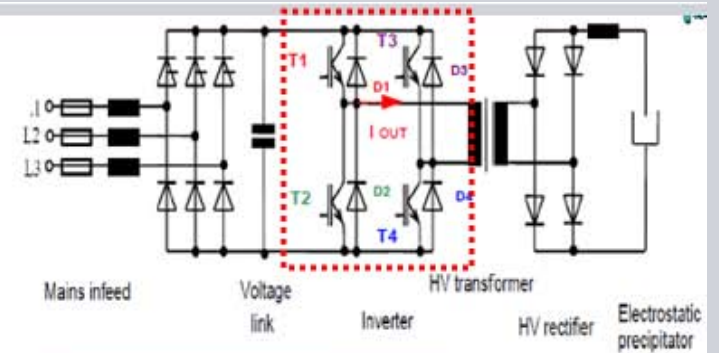
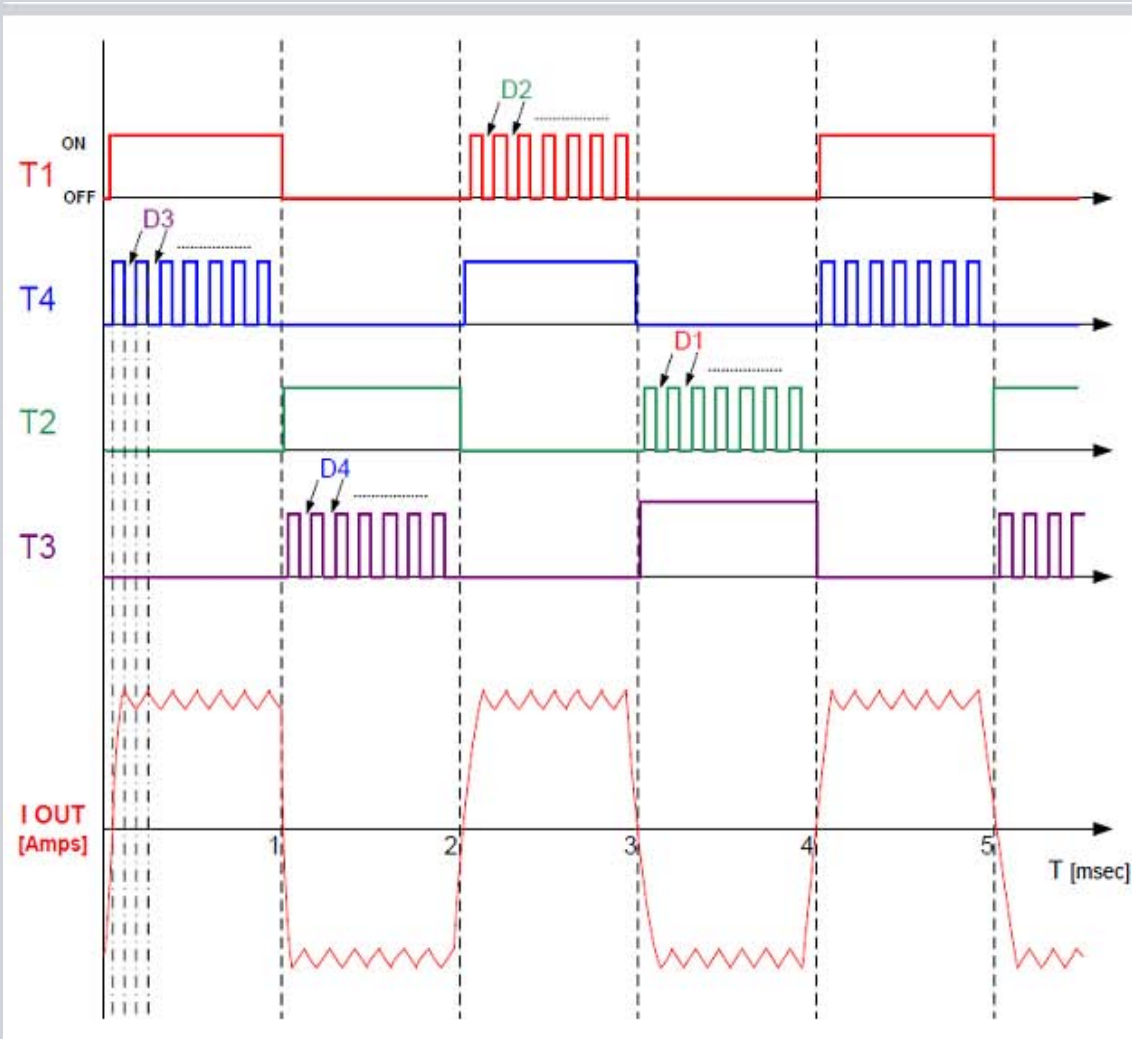

Primary current
T/R set with
field load

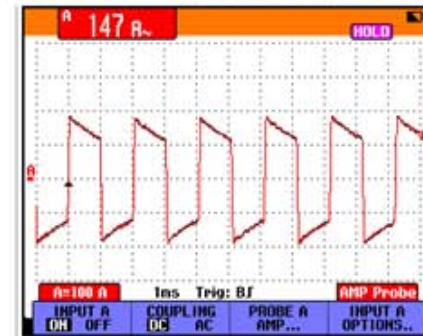

Primary current
T/R set with
secondary
short circuit

SMPS – Switch Mode Power Supply Typical Operating Wave Forms

SIEMENS

500Hz switching frequency

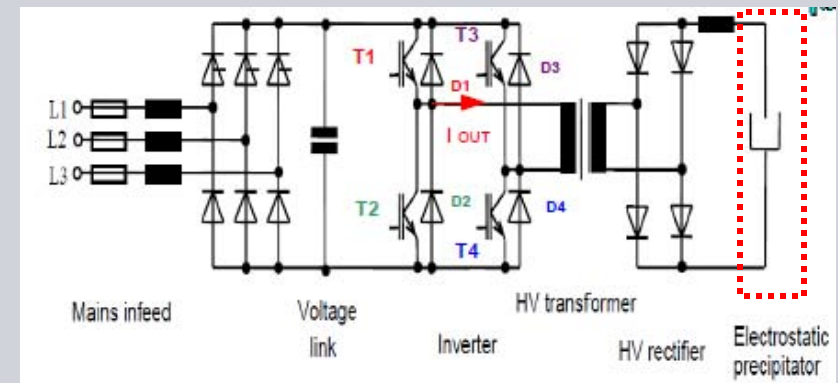
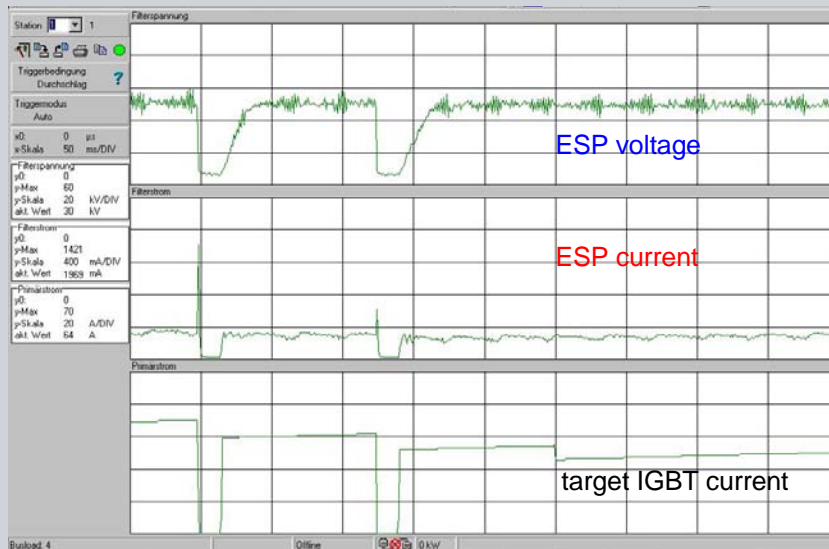

60Hz switching frequency and reuse of existing T/R set

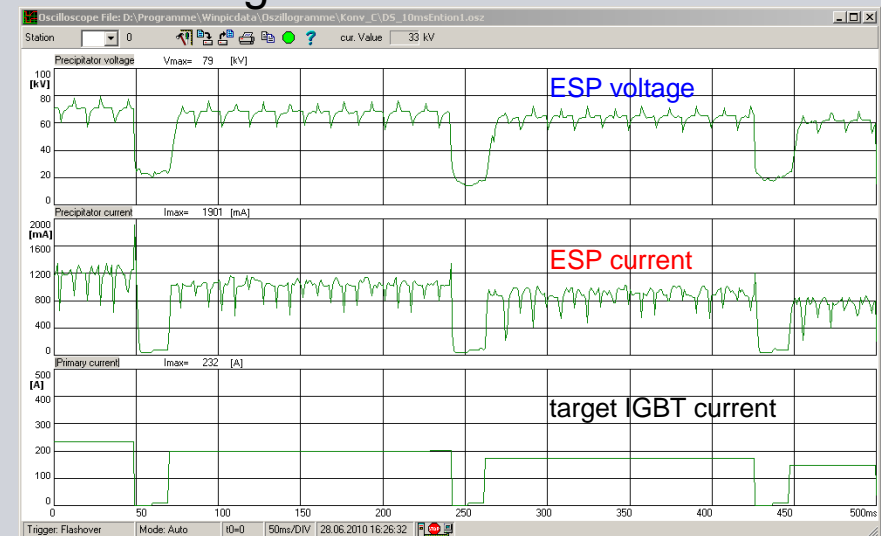

SMPS – Switch Mode Power Supply T/R set Reliability and Maintenance



T/R sets do have a high reliability (proven technology) and are nearly maintenance-free except for the following standard occasional checks:

- oil level
- damage of paintwork
- dust deposits (cleaning of HV bushing)
- cable for condition and proper connection
- T/R set protection devices for proper functioning

With hermetically sealed T/R sets no insulating fluid check is required.

SMPS – Switch Mode Power Supply IGBT Control Cabinet Reliability and Maintenance



IGBT control cabinets do also show a high reliability (experience from 18 years of operation). The following maintenance work needs to be carried out:

- dust deposits should be removed from inside the unit at least once a year
- optional existing filter mats of the cabinet ventilation should be cleaned in intervals according to site conditions
- power cable should be checked for proper connection
- the cooling fan is suggested to be exchanged after approx. 70,000 operation hours
- the thyristor & IGBT modules and voltage link capacitors are suggested to be exchanged depending on the operating conditions after approx. 70,000 operating hours

Siemens ESP Power Supply History

- 1919: rotating mechanical rectifiers
- 1928: first selenium rectifier
- 1931: controlled mercury vapor tube as the first electro-mechanic ESP controller
- 1955: 2-phase AC transducer controlled by variable transformer
- 1968: 2-phase and 3-phase AC transducer with thyristor control
- 1969: 2-phase AC thyristor control with analog controller
- 1979: 1st μ sec pulsing system with oscillating circuit
- 1982: 1st generation microprocessor based thyristor controller
- 1988: 3-phase AC transistor controlled inverter 1kHz; 2nd generation thyristor controller
- 1992: 3-phase AC IGBT controlled inverter 500Hz
- 1993: 3rd generation thyristor controller
- 1997: 2-phase AC compact SCR thyristor power packs & controls
- 1999: 2nd generation μ sec pulsing system with Cavatron pseudospark vacuum switch
- 2004: 3rd generation μ sec pulsing system with HV IGBT switching stack
- 2006: 2nd generation 3-phase AC IGBT controlled inverter 500Hz with Skiip modules
- 2009: 4th generation thyristor controller
- 2010: 3rd generation 3-phase AC IGBT controlled inverter 500Hz and mobile test unit

SMPS – Switch Mode Power Supply Benefits Mid Frequency Power Supply

SIEMENS

- Increased collection efficiency resulting in lower stack opacity
- Higher power factor which provides energy savings payback especially on larger ESPs
- High performance and reliability
- Possibility to reuse existing T/R sets
- Control cubicle placed in electrical control rooms not in the middle of the dirt
- Solid T/R sets for installation at harsh ambient conditions
- Easy access to all components



SMPS – Switch Mode Power Supply

Why invest in modernizing?

SIEMENS



Clean gas dust content too high

- Changed operating conditions (fuel)
- Decreased emission (opacity) limit



Low reliability

- Obsolete and susceptible T/R-sets/controls
- No Service / Spare parts available etc.



High energy costs

- No energy minimization system installed



SMPS – Switch Mode Power Supply

Determine the Potential prior to Investments

- Simple pre-test with the existing equipment:
 - Opacity signal recording
 - Scanning of static I/V curve
 - Determination of max. ESP voltage/current with SMPS
 - Graph opacity = f (corona power)
 - Determination of opacity decrease

- Trial installation for performance check at real operating conditions

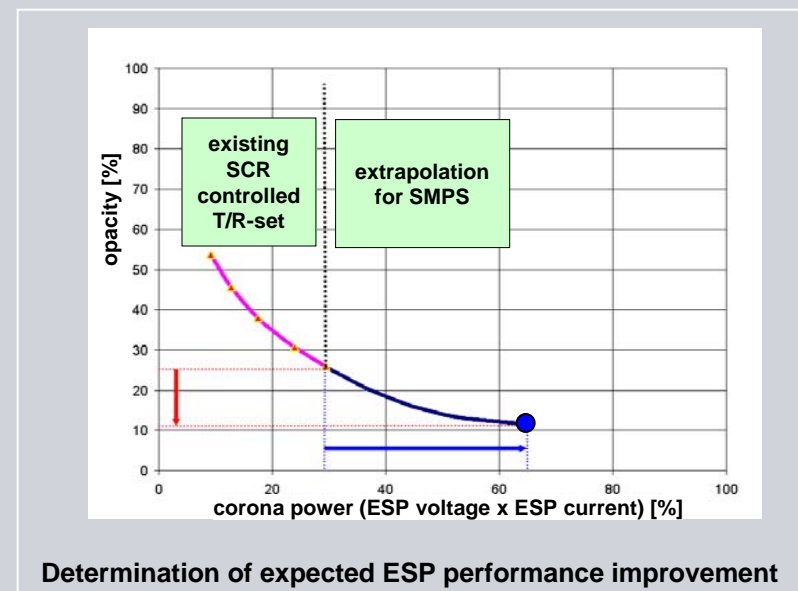
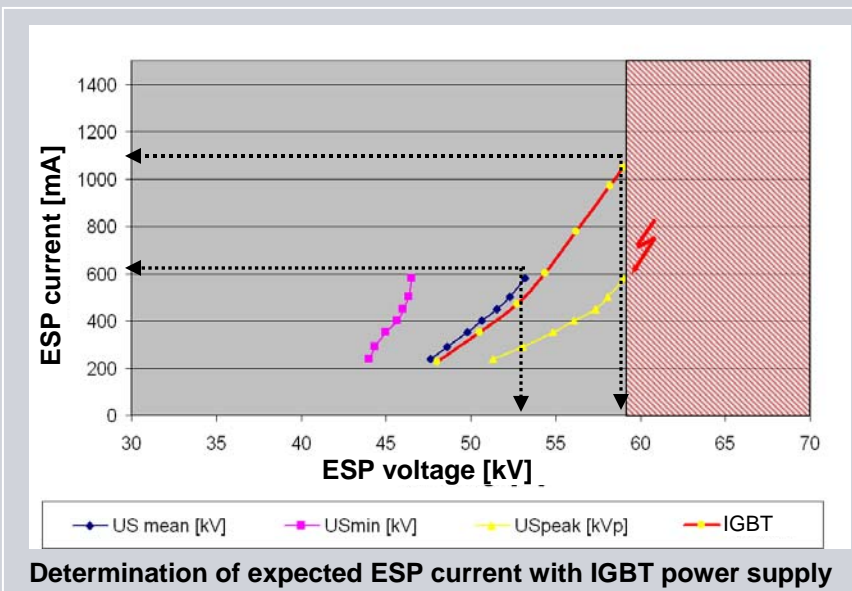

SMPS – Switch Mode Power Supply Trial Installation

SIEMENS

Solution 1:

Siemens offers trial installations with a **Mobile Test Unit**. The container comprises the required equipment for IGBT-technology with **operational and diagnostic software** inclusive all required cables from power supply to data link.



Solution 2:

Alternatively, the individual IGBT-components (IGBT cabinet and TR-Set) and the **operational software** PC-coupling can be used.



SMPS – Switch Mode Power Supply Mobile Test Unit

SIEMENS

The **Mobile Test Unit** is a flexible container solution to determine the potential for maximum ESP performance

- Quick installation and de-installation
- All required equipment on board
- Existing system remains untouched
- Installation of test equipment independent of normal operation
- Only short interruption of operation to connect the high voltage feed
- Supply via high voltage ESP-cable
- Multiple containers in case more than one power supply required

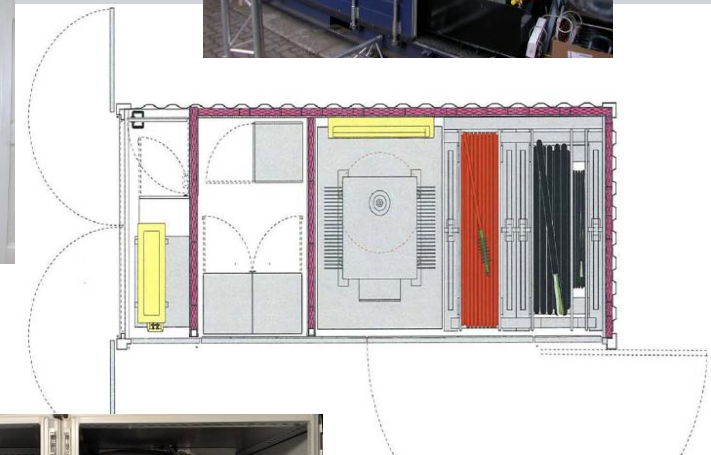

SMPS – Switch Mode Power Supply Possible Configurations



IGBT (500Hz)-operation with a new 60Hz-T/R-Set

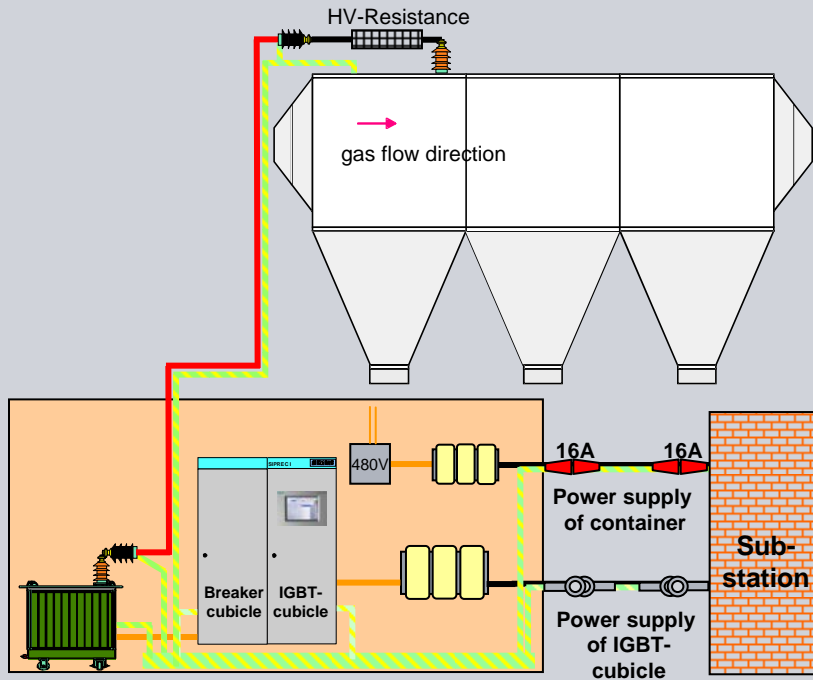

IGBT (500Hz)-operation with the existing 60Hz-T/R-Set

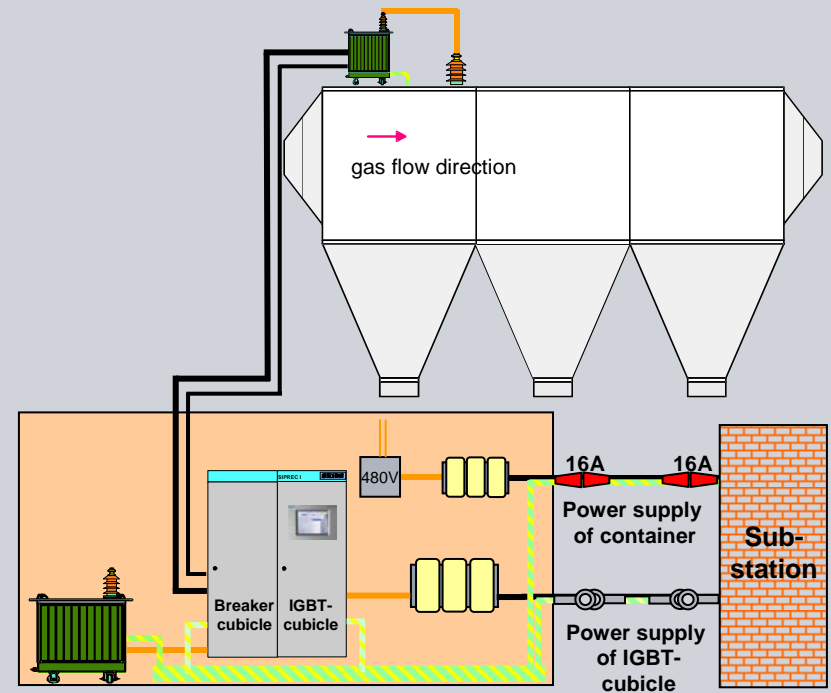

Thank You for Your Attention

Roland Metz

Business Development Manager
Siemens Industry ISD INBU

100 Technology Drive
Alpharetta, GA 30188

phone: +1 (770) 740-3708

fax: +1 (770) 740-3398

cell: +1 (678) 640-4873

E-mail: roland.metz@siemens.com

Dr. Michael Steingräber

Senior Consultant
I IS IN 2 ECO

Günther-Scharowsky-Str. 2
91058 Erlangen

phone: +49 - (9131) 7- 46372

fax: +49 - (9131) 7- 42355

cell: +49 (173) 9772180

E-mail: michael.steingraeber@siemens.com

